

Split Phase Hybrid Storage Inverter

3-9.6 kW









The Afore AF series storage inverters are designed to increase energy independence for homeowners. The power range is from 3.0kW to 9.6kW, compatible with high voltage (80-495V) batteries.

Energy management is based on time-of-use and demand charge rate structures, significantly reduce the amount of energy purchased from public grid.

Thanks for the UPS function (switch time < 10ms), that it enables the crucial loads power on during outages. Additionally, under the backup operation mode, the inverter provides you up to 150% peak output overloading.

The Afore energy storage inverter features Smart Electricity Pricing & Automation, an energy management tool based on real-time electricity pricing strategies. It continuously monitors electricity price fluctuations and dynamically adjusts device operation accordingly. Operating 24/7 fully automatically without the need for manual intervention, it helps users optimize their electricity usage and reduce energy costs.

 AI EMS Electricity Pricing & Automation	 Max. 1.5 PV OVERSIZE 1.5 Times PV Oversize	 3 MPPT MPPT CHANNELS Up to 3 MPPT Channels	<10 ms icon" data-bbox="230 744 263 791"/> <10 ms UPS FUNCTION Switch Time < 10ms	 PARALLEL Max.6 Parallel Stacking	 INPUT Support Generator	 SPLIT-PHASE Support Split-phase (120/240Vac) Grid
	Support for Time-of-use Optimization	Build in Anti-feed-in Function		Configurable Operation Modes	Compact Size and Easy Installation	
	AFCI (Optional) & Rapid Shutdown Ready	Smart Monitoring & Remote Firmware Upgrade				

For New Storage System:

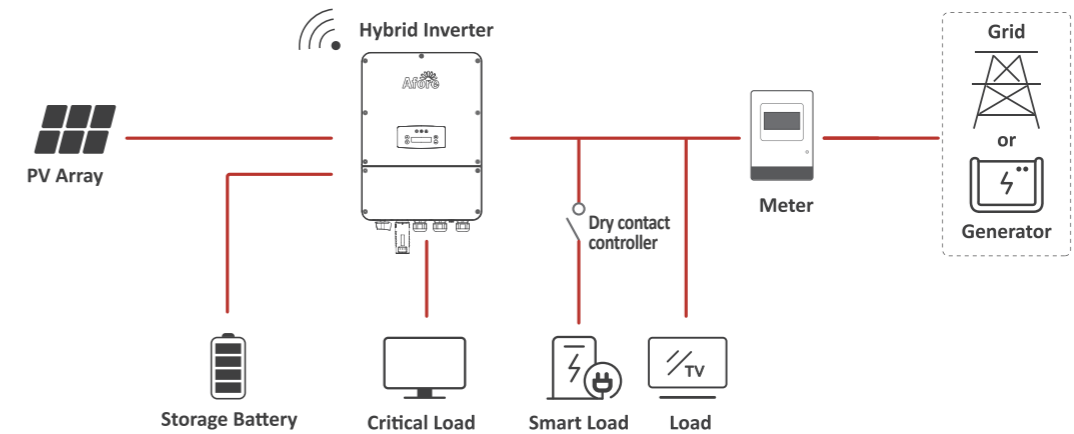

Optimizing Self-Consumption (on-grid) + Emergency Power Supply (off-grid)

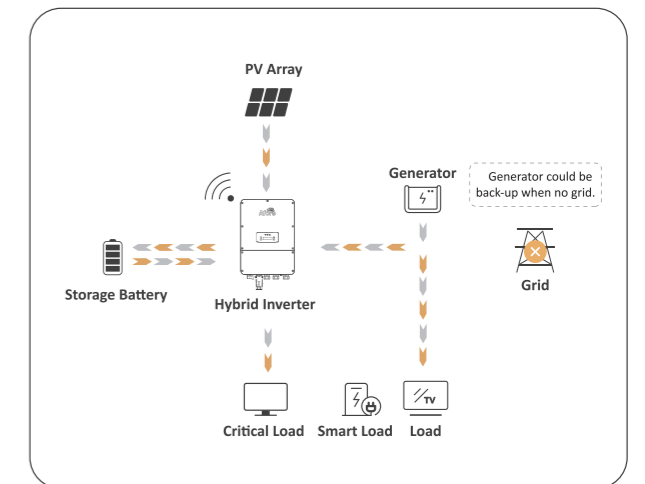
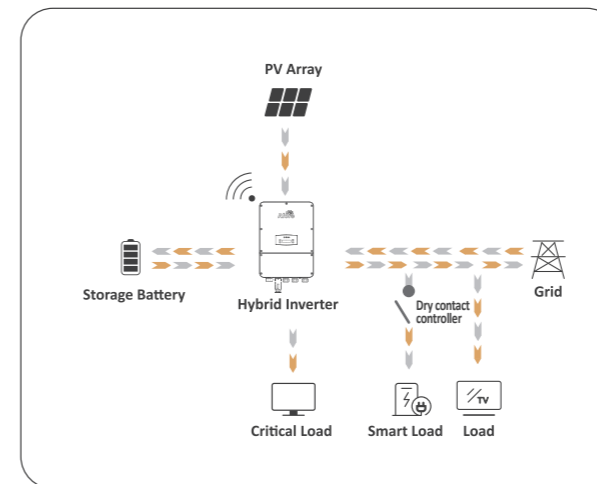

Optimizing Self-Consumption Mode

With home energy storage installed, home owners may also be able to change from a flat rate electricity tariff to a time-of-use tariff. For the areas and regions, where peak shaving can be applied.

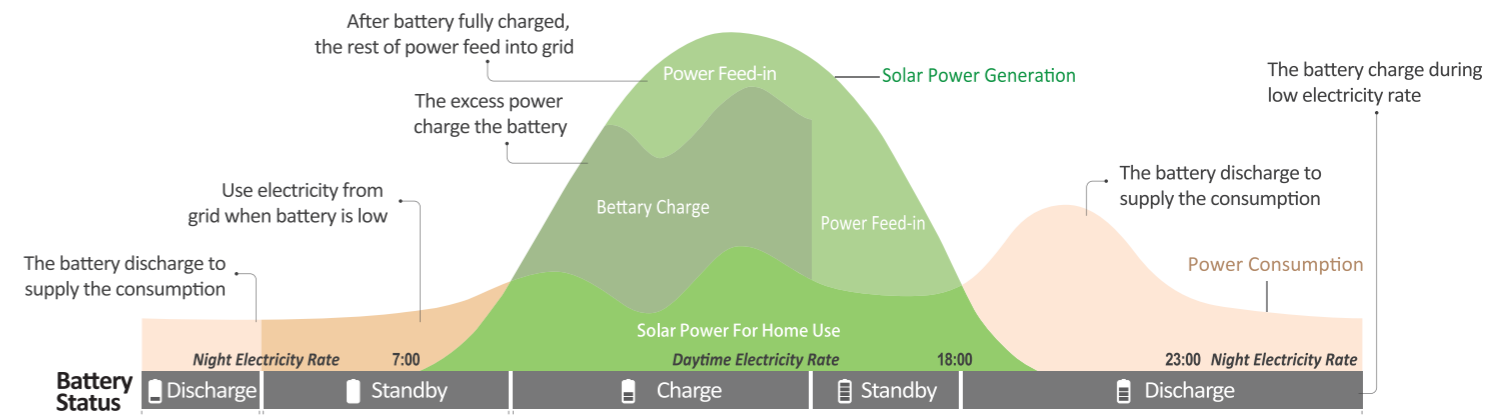

■ Technical Data	AF3K-DH	AF3.6K-DH	AF4K-DH	AF4.6K-DH	AF5K-DH	AF5.5K-DH
PV Input						
Max. Input Power (kW)	4.5	5.4	6.0	6.9	7.5	8.3
Max. PV Voltage (V)	600					
MPPT Range (V)	80 - 550					
Full MPPT Range (V)	110 - 550	135 - 550	150 - 550	170 - 550	185 - 550	200 - 550
Normal Voltage (V)	360					
Startup Voltage (V)	100					
Max. Input Current (A)	15.5 x 2					
Max. Short Current (A)	26.0 x 2					
No. of MPP Tracker / No. of PV String	2 / 2					
Battery Port						
Max. Charge/Discharge Power (kW)	4.5 / 4.5	5.4 / 5.4	6.0 / 6.0	6.9 / 6.9	7.5 / 7.5	8.3 / 8.3
Max. Charge/Discharge Current (A)	50					
Battery Normal Voltage (V)	230					
Battery Voltage Range (V)	80 - 495					
Battery Type	Li-ion / Lead-acid etc.					
AC Grid						
Max Continuous Current (A)	15	17.5	19.5	22.5	24.5	27
Max Continuous Power (kVA)	3.0	3.6	4.0	4.6	5.0	5.5
Nominal Grid Current (A)	12.5 / 14.5	15.0 / 17.4	17.0 / 19.3	19.5 / 22.2	20.9 / 24.1	23.0 / 26.5
Nominal Grid Voltage (V)	211 to 264 @ 240 / 183 to 229 @ 208					
Nominal Grid Frequency (Hz)	60					
Power Factor	1 default (adjustable from 0.8 leading to 0.8 lagging)					
Current THD (%)	< 3					
Gen Input & AC Load Output						
Max. Continuous Current (A)	15	17.5	19.5	22.5	24.5	27
Max. Continuous Power (kVA)	3.0	3.6	4.0	4.6	5.0	5.5
Max. Peak Current (A) (10min)	18.8 / 21.7	22.5 / 26.0	25 / 28.9	28.8 / 33.2	31.3 / 36.1	34.6 / 39.9
Max. Peak Power (kVA) (10min)	4.5 / 4.5	5.4 / 5.4	6.0 / 6.0	6.9 / 6.9	7.5 / 7.5	8.3 / 8.3
Nominal AC Voltage L-L (V)	240 / 208					
Nominal AC Voltage L-N (V)	120 / 104					
Nominal AC Frequency (Hz)	60					
Switching Time (ms)	< 10					
Voltage THD (%)	< 3					
Efficiency						
CEC Efficiency (%)	97.0					
Max. Efficiency (%)	97.6					
PV to Bat. Efficiency (%)	98.1					
Bat. between AC Efficiency (%)	96.8					
Protection						
PV Reverse Polarity Protection	Yes					
Bat. Reverse Polarity Protection	Yes					
Over Current/Voltage Protection	Yes					
Anti-Islanding Protection	Yes					
AC Short Circuit Protection	Yes					
Residual Current Detection	Yes					
Ground Fault Monitoring	Yes					
Insulation Resister Detection	Yes					
PV Arc Detection	Yes					
Rapid Shut Down	Yes					
Protection Degree	NEMA4X					
AC/DC surge protection	Type II					
General Data						
Dimensions (W x H x D)	400 x 600 x 229 mm / 15.7 x 23.6 x 9.0 in					
Weight	25 kg / 55 lbs					
Topology	Transformerless					
Cooling	Intelligent Fan					
Relative Humidity	0 - 100 %					
Operating Temperature Range	- 25 to 60 °C / - 77 to 140 °F					
Operating Altitude	< 4000 m / < 13123 ft					
Standby Consumption (W)	< 10					
Mounting	Wall Bracket					
Communication with RSD	SUNSPEC					
Display & Communication Interfaces	LCD, LED, RS485, CAN, Wi-Fi, GPRS, 4G, Sunspec					
Certification & Approvals	UL 1741 SA, UL 1741, UL1699B, UL 1998, IEEE1547, IEEE1547A, IEEE1547.1, CSA 22.2 No.107, Rule21, HECO Rule 14					
EMC	FCC part15 CLASS B					

■ Technical Data	AF6K-DH	AF7K-DH	AF7.6K-DH	AF8K-DH	AF8.6K-DH	AF9.6K-DH
PV Input						
Max. Input Power (kW)	9.0	10.5	11.4	12.0	12.9	15.0
Max. PV Voltage (V)	600					
MPPT Range (V)	80 - 550					
Full MPPT Range (V)	220 - 550	170 - 550	185 - 550	195 - 550	210 - 550	235 - 550
Normal Voltage (V)	360					
Startup Voltage (V)	100					
Max. Input Current (A)	15.5 x 2					15.5 x 3
Max. Short Current (A)	26.0 x 2					26.0 x 3
No. of MPP Tracker / No. of PV String	2 / 2					3 / 3
Battery Port						
Max. Charge/Discharge Power (kW)	9.0 / 9.0	10.5 / 10.3	11.4 / 10.3	11.5 / 10.3	11.5 / 10.3	11.5 / 10.3
Max. Charge/Discharge Current (A)	50					
Battery Normal Voltage (V)	230					
Battery Voltage Range (V)	80 - 495					
Battery Type	Li-ion / Lead-acid etc.					
AC Grid						
Max Continuous Current (A)	29.0	34.0	37	39	41.5	46.5
Max Continuous Power (kVA)	6.0	7.0	7.6	8.0	8.6	9.6
Nominal Grid Current (A)	25.0 / 28.9	29.2 / 33.7	31.7 / 36.6	33.4 / 38.5	35.9 / 41.4	40.0 / 46.2
Nominal Grid Voltage (V)	211 to 264 @ 240 / 183 to 229 @ 208					
Nominal Grid Frequency (Hz)	60					
Power Factor	1 default (adjustable from 0.8 leading to 0.8 lagging)					
Current THD (%)	< 3					
Gen Input & AC Load Output						
Max. Continuous Current (A)	29.0	34.0	37	39	41.5	46.5
Max. Continuous Power (kVA)	6.0	7.0	7.6	8.0	8.6	9.6
Max. Peak Current (A) (10min)	37.5 / 43.3	43.8 / 49.5	47.5 / 49.5	47.9 / 49.5	47.9 / 49.5	47.9 / 49.5
Max. Peak Power (kVA) (10min)	9.0 / 9.0	10.5 / 10.3	11.4 / 10.3	11.5 / 10.3	11.5 / 10.3	11.5 / 10.3
Nominal AC Voltage L-L (V)	240 / 208					
Nominal AC Voltage L-N (V)	120 / 104					
Nominal AC Frequency (Hz)	60					
Switching Time (ms)	< 10					
Voltage THD (%)	< 3					
Efficiency						
CEC Efficiency (%)	97.0					
Max. Efficiency (%)	97.6					
PV to Bat. Efficiency (%)	98.1					
Bat. between AC Efficiency (%)	96.8					
Protection						
PV Reverse Polarity Protection	Yes					
Bat. Reverse Polarity Protection	Yes					
Over Current/Voltage Protection	Yes					
Anti-Islanding Protection	Yes					
AC Short Circuit Protection	Yes					
Residual Current Detection	Yes					
Ground Fault Monitoring	Yes					
Insulation Resister Detection	Yes					
PV Arc Detection	Yes					
Rapid Shut Down	Yes					
Protection Degree	NEMA4X					
AC/DC surge protection	Type II					
General Data						
Dimensions (W x H x D)	400 x 600 x 229 mm / 15.7 x 23.6 x 9.0 in					
Weight	25 kg / 55 lbs					
Topology	Transformerless					
Cooling	Intelligent Fan					
Relative Humidity	0 - 100 %					
Operating Temperature Range	- 25 to 60 °C / - 77 to 140 °F					
Operating Altitude	< 4000 m / < 13123 ft					
Standby Consumption (W)	< 10					
Mounting	Wall Bracket					
Communication with RSD	SUNSPEC					
Display & Communication Interfaces	LCD, LED, RS485, CAN, Wi-Fi, GPRS, 4G, Sunspec					
Certification & Approvals	UL 1741 SA, UL 1741, UL1699B, UL 1998, IEEE1547, IEEE1547A, IEEE1547.1, CSA 22.2 No.107, Rule21, HECO Rule 14					
EMC	FCC part15 CLASS B					